

B900 SERIES USER MANUAL
CLASS B AIS Identifier

Applicable models B921 / B922 / B923 / B924 / B951 / B952 / B953 / B954



CONTENT

1 NOTICES	5
1.1 Safety warnings	5
1.2 General notices	5
1.3 Important information for US customers	6
1.4 Innovation, Science and Economic Development Canada	7
2 ABOUT AIS	8
2.1 Static and dynamic vessel data	9
3 ABOUT YOUR AIS TRANSCEIVER	10
3.1 Overview	10
3.2 B900 product range	12
3.2.1 Main features	12
3.3 What's in the box?	13
3.4 Support and warranty	13
3.5 Configuration tools	13
4 INSTALLATION	14
4.1 Summary	14
4.2 Antennas	15
4.2.1 VHF antenna	15
4.2.2 GPS antenna	16
4.3 Power	17
4.3.1 Connecting power and data cable	17
4.4 Location and fixing of the transceiver	19
4.5 Configuration	21
4.5.1 Switching on your AIS transceiver for the first time	21
4.5.2 Configuring your AIS transceiver	21
4.6 Introduction to proAIS2	21
4.6.1 Installing proAIS2	22
4.6.2 Vessel data configuration using proAIS2	22
4.6.3 Wi-Fi configuration using proAIS2	22
4.6.4 Access point mode	22
4.6.5 Station mode	23
4.6.6 Bluetooth	23
4.6.7 Introduction to CONNECT-AIS	24
4.7 Connectivity	24
4.7.1 Connecting to an NMEA 2000 network	24
4.7.2 Connecting to your chartplotter	25

4.8 Connecting to your NMEA 0183 sensor	26
4.8.1 Connecting to your PC	26
4.8.2 Wi-Fi and Bluetooth connectivity	27
 5 OPERATION	28
5.1 LED indicators	28
5.1.1 Using the AIS transceiver	28
5.1.2 LED indicator functions	28
5.2 Silent mode	29
5.3 PGN table	30
5.3.1 NMEA conversions	31
 6 TROUBLESHOOTING	33
 7 SPECIFICATIONS	35

I FIGURES

<i>Figure 1 : The AIS network</i>	9
<i>Figure 2 : AIS transceiver overview</i>	10
<i>Figure 3 : Transceiver dimensions</i>	10
<i>Figure 4 : FLEXI-FIT bracket</i>	11
<i>Figure 5 : Package contents</i>	13
<i>Figure 6 : Typical Installation configuration</i>	14
<i>Figure 7 : VHF antenna connector</i>	15
<i>Figure 8 : GPS antenna connector</i>	16
<i>Figure 9 : Power and data cable connections</i>	17
<i>Figure 10 : Connecting the power supply</i>	18
<i>Figure 11 : Transceiver dimensions</i>	19
<i>Figure 12 : FLEXI-FIT bracket</i>	20
<i>Figure 13 : AIS transceiver mounting</i>	20
<i>Figure 14 : Configuration using your P.C</i>	21
<i>Figure 15 : Configuration using your smartphone</i>	21
<i>Figure 16 : Typical mobile devices for Wi-Fi & Bluetooth connection</i>	23
<i>Figure 17 : NMEA 2000 network connection</i>	24
<i>Figure 18 : Connecting to your chartplotter</i>	25
<i>Figure 19 : Connecting to your NMEA 0183 sensor</i>	26
<i>Figure 20 : Connecting to your PC</i>	26
<i>Figure 21 : LED indicator location on the AIS transceiver unit</i>	28
<i>Figure 22 : Connecting an external switch</i>	30

1 Notices



When reading this manual pay attention to warnings marked with the warning triangle shown on the left. These are important messages for safety, installation and usage of the product.

1.1 Safety warnings



This equipment must be installed in accordance with the instructions provided in this manual.



This AIS transceiver is an aid to navigation and must not be relied upon to provide accurate navigation information. AIS is not a replacement for vigilant human lookouts and other navigation aids such as RADAR. The performance of the transceiver may be seriously impaired if not installed as instructed in the user manual, or due to other factors such as weather and or nearby transmitting devices.

Compatibility with other systems may vary and is reliant on the third party systems recognising the standard outputs from the transceiver. The manufacturer reserves the right to update and change these specifications at any time.



Do not install this equipment in a flammable atmosphere such as in an engine room or near fuel tanks.

1.2 General notices

Position source

All marine Automatic Identification System (AIS) transceivers utilise a satellite based location system, which is referred to as Global Navigation Satellite System (GNSS). This includes Global Positioning System (GPS), Globalnaya Navigazionnaya Sputnikovaya Sistema (GLONASS), Galileo, and BeiDou.

The accuracy of a GPS position fix is variable and is affected by factors such as the antenna positioning, how many satellites are used to determine a position and for how long satellite information has been received for.

The term GPS will be used in this manual to mean all and any GNSS systems.

Compass safe distance

The compass safe distance of this unit is 0.2m or greater for 0.3° deviation.

RF emissions notice

Caution: The AIS transceiver generates and radiates radio frequency electromagnetic energy. This equipment must be installed and operated according to the instructions contained in this manual. Failure to do so can result in personal injury and / or AIS transceiver malfunction.

Caution: Never operate the AIS transceiver unless it is connected to a VHF antenna.

To maximise performance and minimise human exposure to radio frequency electromagnetic energy you must make sure that the antenna is mounted at least 1.5 metres away from the AIS transceiver and is connected to the AIS transceiver before power is applied. The system has a Maximum Permissible Exposure (MPE) radius of 1.5m. This has been determined assuming the maximum power of the AIS transceiver and using antennas with a maximum gain of 3DeciBel Isotropic (dBi). The antenna should be mounted 3.5m above the deck in order to meet RF exposure requirements. Higher gain antennas will require a greater mean percentage error (MPE) radius. Do not operate the unit when anyone is within the MPE radius of the antenna (unless they are shielded from the antenna field by a grounded metallic barrier). The antenna should not be co-located or operated in conjunction with any other transmitting antenna. The required antenna impedance is 50 Ohms.

Disposal of this product and packaging

Dispose of the AIS transceiver in accordance with the European Waste Electrical and Electronic Equipment recycling (WEEE) Directive or with the applicable local regulations for disposal of electrical equipment.

Every effort has been made to ensure the packaging for this product is recyclable. Dispose of the packaging in an environmentally friendly manner.

Accuracy of this manual

The AIS transceiver may be upgraded from time to time and future versions of the AIS transceiver may therefore not correspond exactly with this manual. Information contained in this manual is liable to change without notice. The manufacturer of this product disclaims any liability for consequences arising from omissions or inaccuracies in this manual and any other documentation provided with this product.

Radio Equipment Directive

The manufacturer of this product declares that this product is in compliance with the essential requirements and other provisions of the Radio Equipment Directive 2014/53/EU and as such displays the CE mark. The RED declaration of conformity is provided as part of this documentation pack.

The manufacturer declares that this product complies with the United Kingdom Conformity Assessed requirements and as such, displays the UKCA mark. The UKCA declaration of conformity is provided as part of this documentation pack.



FCC Notice

This equipment has been tested and found to comply with the limits for a class B digital device, pursuant to part 15 of the FCC Rules. These limits are designed to provide reasonable protection against harmful interference in a residential installation. This equipment generates, uses and can radiate radio frequency energy and, if not installed and used in accordance with the instructions, may cause harmful interference to radio communications.

This device complies with part 15 of the FCC Rules. Operation is subject to the following two conditions: (1) This device may not cause harmful interference, and (2) this device must accept any interference received, including interference that may cause undesired operation.

Changes or modifications not expressly approved by the party responsible for compliance could void the user's authority to operate the equipment.



WARNING: It is a violation of the rules of the Federal Communications Commission to input an MMSI that has not been properly assigned to the end user, or to otherwise input any inaccurate data in this device.

1.3 Important information for US customers

US CUSTOMERS ONLY: In the USA it is illegal for an end user to configure their own AIS with their vessel data. To do so is a violation of the rules of the United States Coast Guard (USCG). This must be done by a competent installer, such as em-trak, an em-trak dealer or competent marine electronics professional. If your transceiver has not been pre-configured for you, refer to your dealer or contact support@em-trak.com for advice on how to have the transceiver configured legally. If purchasing direct from em-trak online we can configure it for you and dispatch it pre-configured at no extra cost, if you are purchasing from one of our dealers, then they will do it for you.



In the United States of America, the MMSI and static data must only be entered by a competent installer. The end user of the equipment is not authorised to enter their own vessel data.

1.4 Innovation, Science and Economic Development Canada

This device contains licence-exempt transmitter(s)/receiver(s) that comply with Innovation, Science and Economic Development Canada's licence-exempt RSS(s). Operation is subject to the following two conditions:

1. This device may not cause interference.
2. This device must accept any interference, including interference that may cause undesired operation of the device.

L'émetteur/récepteur exempt de licence contenu dans le présent appareil est conforme aux CNR d'Innovation, Sciences et Développement économique Canada applicables aux appareils radio exempts de licence. L'exploitation est autorisée aux deux conditions suivantes:

1. L'appareil ne doit pas produire de brouillage;
2. L'appareil doit accepter tout brouillage radioélectrique subi, même si le brouillage est susceptible d'en compromettre le fonctionnement.

2 About AIS

The marine Automatic Identification System (AIS) is a location and vessel information reporting system. It allows vessels equipped with AIS to automatically and dynamically share and regularly update their position, speed, course and other information such as vessel identity with similarly equipped vessels. Position is derived from the Global Navigation Satellite System (GNSS) and communication between vessels is by Very High Frequency (VHF) digital transmissions.

There are a number of types of AIS device as follows:

- Class A transceivers. These are similar to class B transceivers, but are designed to be fitted to large vessels such as cargo ships and large passenger vessels. Class A transceivers transmit at a higher VHF signal power than class B transceivers and therefore can be received by more distant vessels. They also transmit Class A transceivers are mandatory on all vessels over 300 gross tonnes on international voyages and certain types of passenger vessels under SOLAS regulations.
- Class B transceivers. Similar to class A transceivers in many ways, but are normally lower cost due to the less stringent performance requirements. Class B transceivers transmit at a lower power and at a lower reporting rate than class A transceivers.
- AIS base stations. AIS base stations are used by Vessel Traffic Systems to monitor and control the transmissions of transceivers.
- Aids to Navigation (AtoN) transceivers. AtoN's are transceivers mounted on buoys or other hazards to shipping which transmit details of their location to the surrounding vessels.
- AIS receivers. AIS receivers will generally receive transmissions from class A transceivers, class B transceivers, AtoN's and AIS base stations but do not transmit any information about the vessel on which they are installed.

2.1 Static and dynamic vessel data

There are two categories of information transmitted by a transceiver: static and dynamic data.

The vessel's dynamic data, which includes location, speed over ground (SOG) and course over ground (COG), is calculated automatically using the integrated GPS receiver.

Static data is information about the vessel which must be configured into the AIS transceiver. This includes:

- Maritime Mobile Service Identity (MMSI)
- Vessel name
- Vessel call sign (if available)
- Vessel type
- Vessel dimensions

In most countries the operation of a transceiver is included under the vessel's marine VHF license provisions. The vessel on to which the AIS unit is to be installed must therefore possess a current VHF radiotelephone license which lists the AIS system, vessel Call Sign and MMSI number.

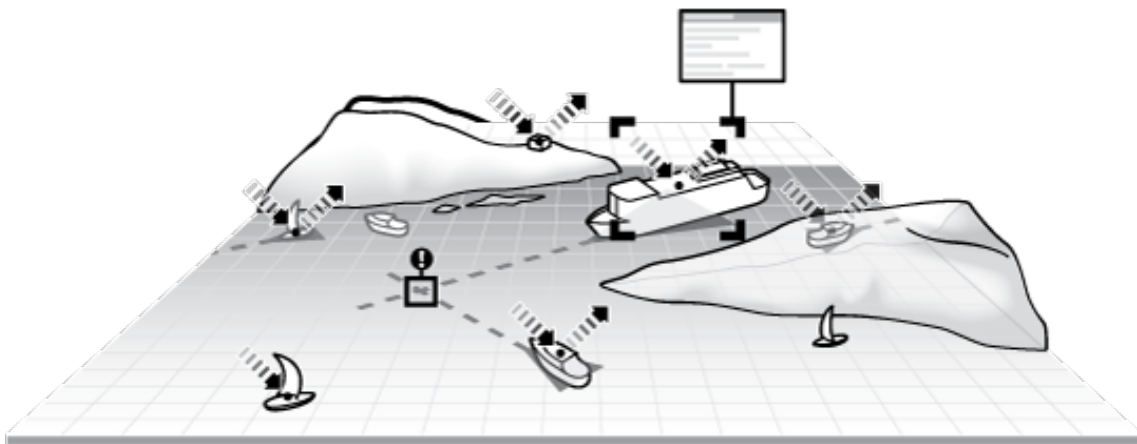
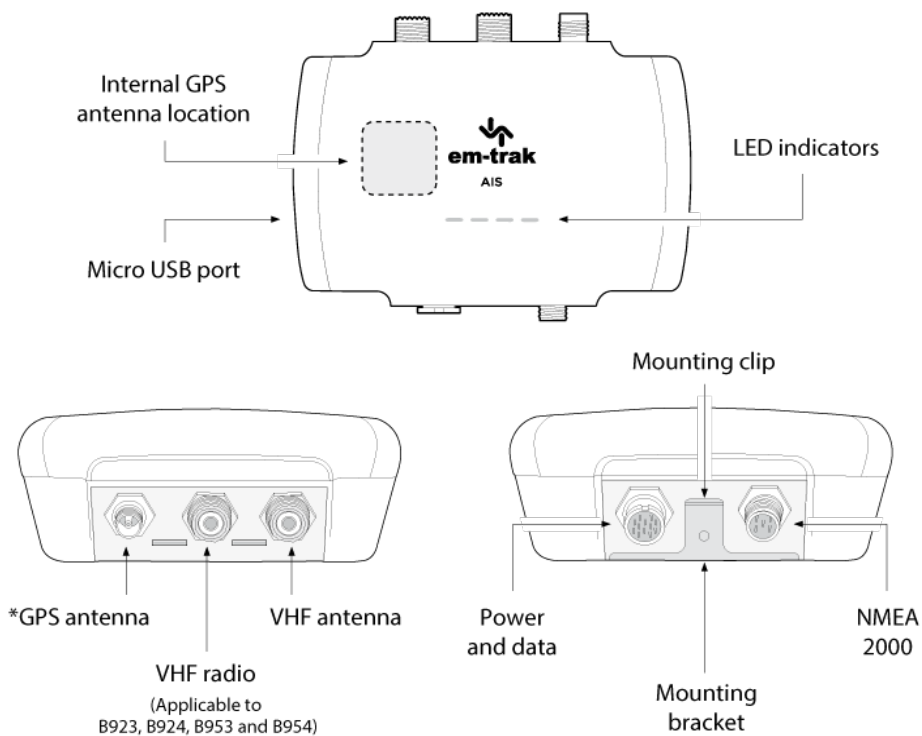

Figure 1 : The AIS network

3 About your AIS transceiver

3.1 Overview



* GPS receiver & antenna supports: GPS, GLONASS, Galileo and BeiDou

Figure 2 : AIS transceiver overview

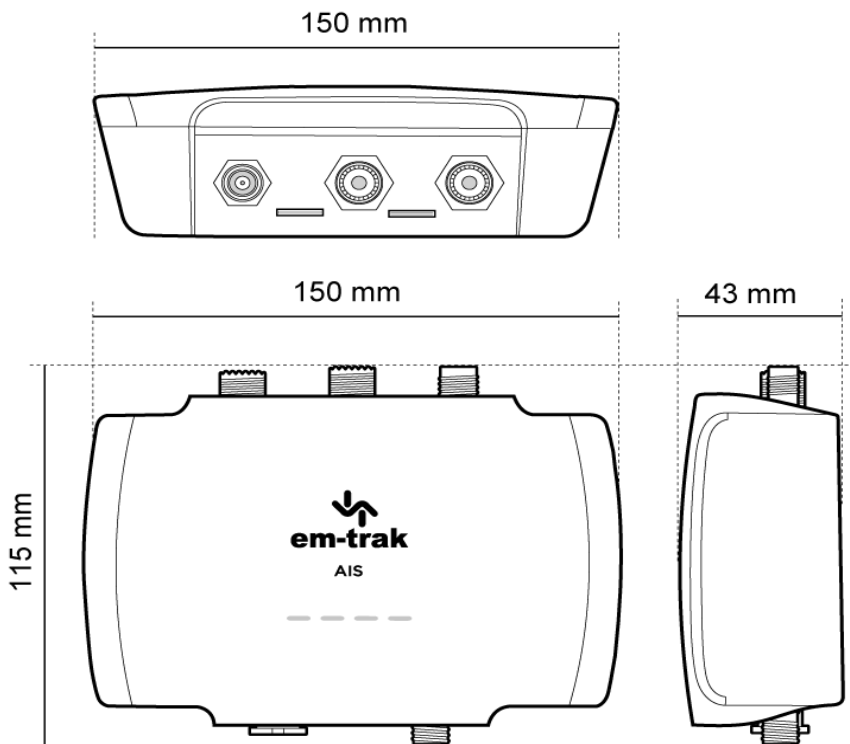

Figure 3 : Transceiver dimensions

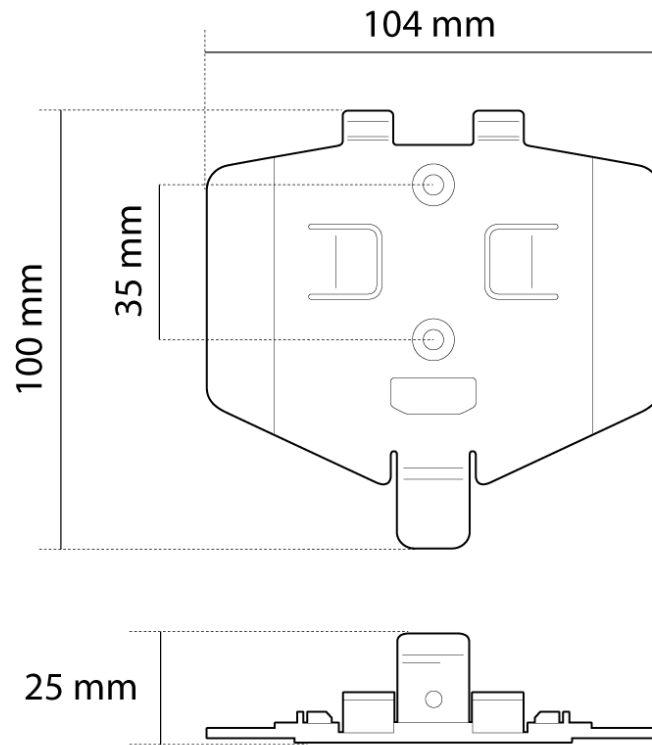

Figure 4 : FLEXI-FIT bracket

3.2 B900 product range

The B900 Series provides multiple feature options. The variants and main features are detailed below.

Feature options	B921	B922	B923	B924	B951	B952	B953	B954
2W CSTDMA	✓	✓	✓	✓				
5W SOTDMA					✓	✓	✓	✓
Water & weather proof (IPx6 & IPx7)	✓	✓	✓	✓	✓	✓	✓	✓
FLEX-FIT bracket	✓	✓	✓	✓	✓	✓	✓	✓
Integrated GPS receiver & antenna	✓	✓	✓	✓	✓	✓	✓	✓
Integrated VHF antenna splitter			✓	✓			✓	✓
Wi-Fi & Bluetooth		✓		✓		✓		✓
NMEA2000 NMEA 0183, & USB	✓	✓	✓	✓	✓	✓	✓	✓

3.2.1 Main features

- Integrated Wi-Fi & Bluetooth so you can connect wirelessly to all your devices. Applicable to B922/B924/B952/B954.
- Integrated VHF antenna splitter so you can use your existing VHF radio antenna. Applicable to B923/B924/B953/B954.
- Integrated high performance GPS receiver and antenna so that an external GPS antenna is optional.
- FLEXI-FIT™ bracket to make installation on any boat simple, safe and secure.
- IPx7 tested and certified for complete water submersion and IPx6 tested and certified for high pressure spray. The B900 series is able to be installed and operated permanently outdoors in a fully exposed location or in a location where it will be exposed to extreme hot or cold temperatures, damp, salt air and water.
- NMEA 2000, NMEA 0183 & USB so you can connect to any chart plotter, sensor, PC or laptop application that supports AIS.

3.3 What's in the box?

Figure 5 shows the items included with the product. If any of the items are not present contact your dealer or support@em-trak.com.

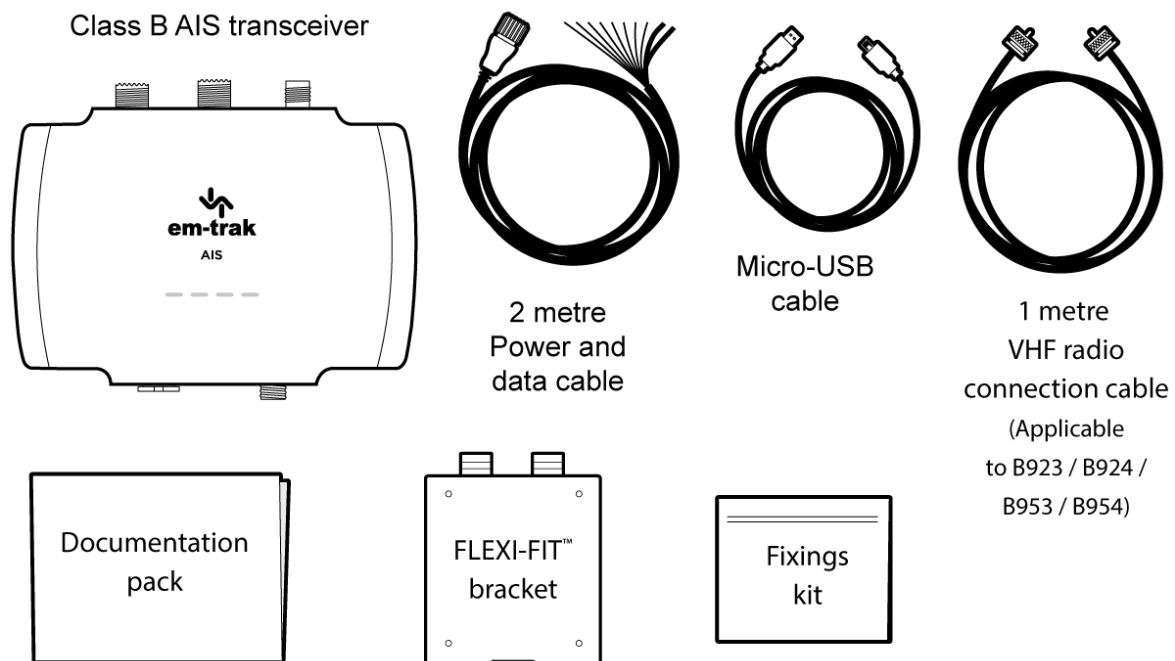

Figure 5 : Package contents

3.4 Support and warranty

If you are unhappy with your product, within two days of receipt and subject to the product and packaging being complete and undamaged, it may be returned for a full refund. We cannot accept the return of any product if you have not advised us in writing within 48 hours of receiving your em-trak product, or if it has been used and or damaged or if any of the package is incomplete. All em-trak products benefit from our three year global warranty.

In the unlikely event of a problem, contact our Customer Support department at support@em-trak.com and one of our experts will work with you to resolve your issue or arrange the repair or replacement of your em-trak product. The warranty is invalidated if the product has been incorrectly used, damaged or tampered. We recommend visiting www.em-trak.com/support to access the product FAQs, and to download user manuals and documentation.

3.5 Configuration tools

Your AIS transceiver will need to be configured with your vessel details before it will start transmitting and working correctly. To do that you will need to either download proAIS2 to your PC or laptop (from www.em-trak.com/installation), or download CONNECT-AIS to your smartphone from Google Play or the App Store.

Any variant can be configured using proAIS2 and the Micro-USB cable (supplied). More detail on proAIS2 and the configuration process can be found in "Configuring your AIS transceiver" on page 21.

The B922/B924/B952/B954 can be configured wirelessly using either Bluetooth or Wi-Fi. More detail on CONNECT-AIS can be found in "Configuring your AIS transceiver" on page 21.

4 Installation

4.1 Summary

Before beginning installation of your transceiver, ensure you have any necessary additional items as detailed below. It is strongly recommended that you read all of the instructions in this manual prior to installation. If after reading this manual you are unsure about any element of the installation process, contact your dealer or support@em-trak.com for advice.

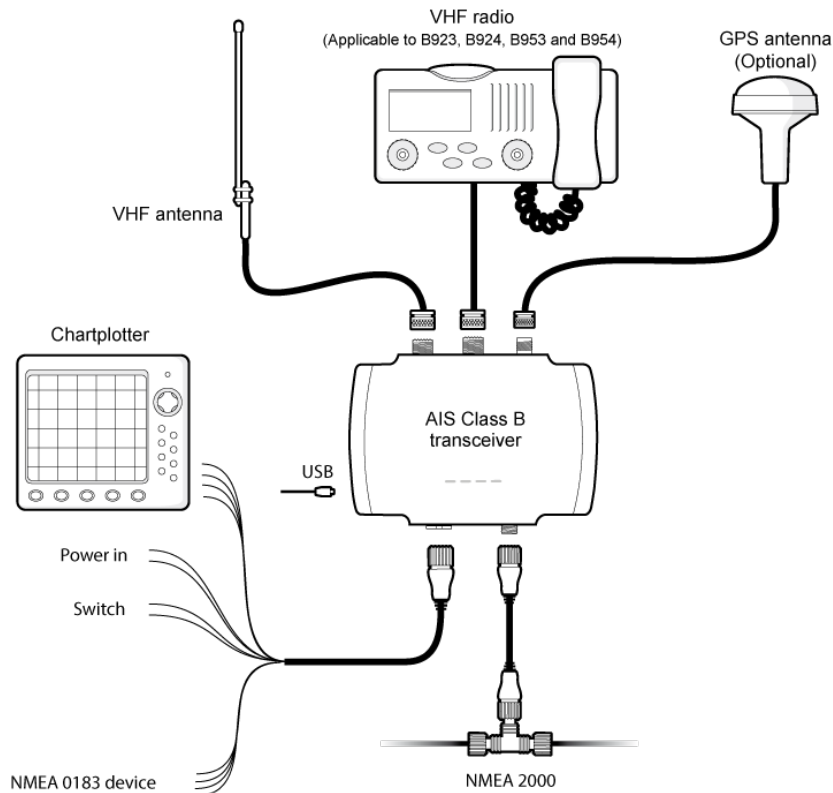

Figure 6 : Typical Installation configuration

In addition to the items supplied, the following may also be required for your installation:

- VHF antenna and cable - this is required for your transceiver to receive and transmit. A variant with an integrated splitter (B923/B924/B953/B954) can use an existing VHF antenna providing it is tuned to operate across the frequency range 156MHz to 162MHz. VHF antenna installation is covered in more detail in "VHF antenna" on the facing page. If you need to extend the antenna cable when connecting to your existing VHF antenna, RG-58 or RG-8X can be used for short distances. For longer runs we would recommend a low loss cable like RG-213.
- External GPS antenna - this may be required if your installation location is deep inside your boat where the Integrated GPS receiver and antenna will not be able to receive satellite signals. GPS antenna installation is covered in more detail in "GPS antenna" on page 16.
- Power cable - this may be required to extend the length of the 2m power and data cable that is supplied with your transceiver. If you require longer cables to reach your power supply, ensure they are capable of carrying currents of up to 2.5A peak and 220mA on average. Connecting the power supply is covered in more detail in "Connecting power and data cable" on page 17.

- Toggle switch - this can be used to turn on/off silent mode. We would recommend a latching toggle switch for this application. Installation of the toggle switch is covered in more detail in "Silent mode" on page 29. Silent mode can also be controlled using the configuration tools.

4.2 Antennas

4.2.1 VHF antenna

Connection to a suitable VHF antenna will be required for the transceiver to receive and transmit.

Transceiver variants (B921/B922/B951/B952) do not have an integrated splitter and will require a dedicated VHF antenna tuned to the AIS channels at 162MHz.

Integrated splitter variants (B923/B924/B953/B954) will require a VHF antenna tuned to operate across the frequency range 156MHz to 162MHz. That allows it to be compatible with both VHF radio (156MHz) and AIS (162MHz).

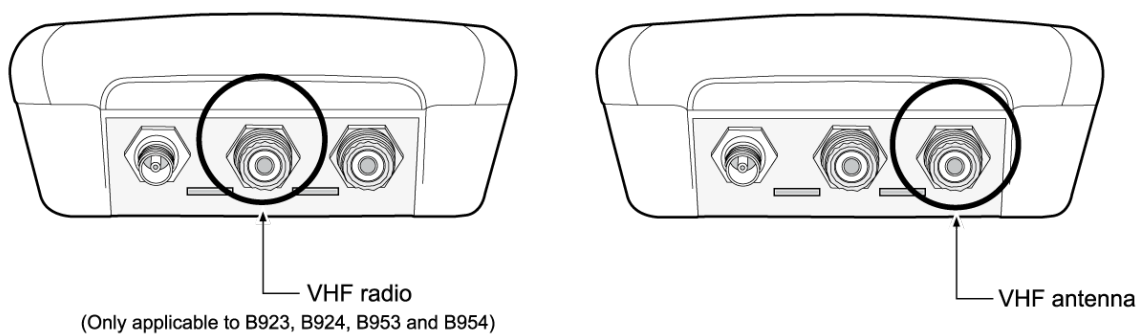

Figure 7 : VHF antenna connector

The VHF antenna connector type is SO-239. It requires a PL-259 mating connector for the antenna.

For optimum performance the VHF antenna should be mounted as high as possible, and as far away as possible from metal structures, obstructions or sources of interference. If another transmitting antenna is installed on the same vessel we would recommend a separation distance of at least 3m where possible.

4.2.2 GPS antenna

All B900 variants have an integrated high-performance GPS receiver & antenna, and are compatible with the GPS, GLONASS, Galileo, and BeiDou satellite navigation systems. A multi GPS mode can be enabled using proAIS2, allowing you to select combinations of the above systems. This will provide a more stable position fix, and also offers redundancy if one of the satellite systems goes offline. If you install it near a window, under a fiberglass deck or inside a centre console, you will not require an external GPS antenna. If your installation location is deep inside your boat where the GPS antenna will not be able to receive satellite signals you will need an external GPS antenna. We recommend the em-trak GPS100, which is available for purchase from www.em-trak.com.

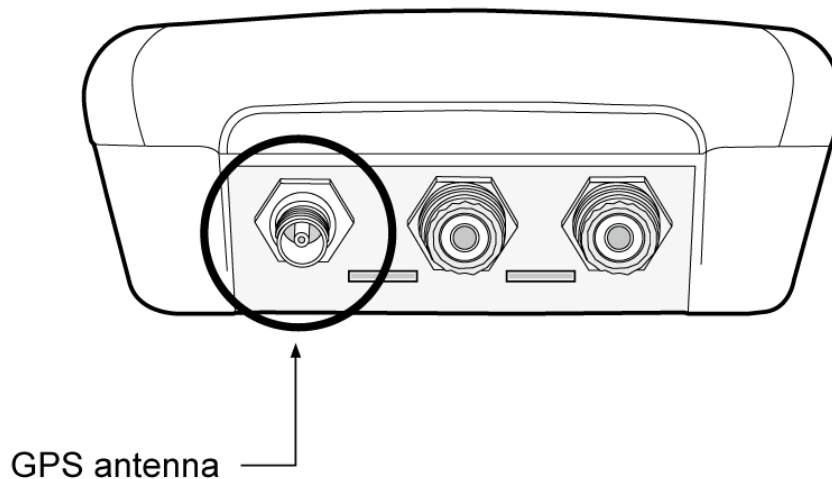

Figure 8 : GPS antenna connector

Note the following guidelines when installing an external GPS antenna.

- You will require a 1" (inch) 14 Threads per inch (TPI) threaded mount if you choose to pole mount the GPS antenna.
- The GPS antenna is also supplied with a gasket/thumb nuts/ studs so it can be deck mounted. The gasket can be used as a mounting template if required.
- Mounting the external GPS antenna at a low point on the boat will minimise the effect of pitch and roll on your transmitted position.
- Do not mount your antenna in the direct path of a radar or any other transmitting equipment.

4.3 Power

4.3.1 Connecting power and data cable

A power and data cable is supplied with the product to provide connections for power, two NMEA 0183 data ports and the optional silent mode switch. The cable has a moulded connector at one end which should be connected to the 12 pin connector on the unit. The other end of the cable has 12 colour coded bare wires ready for connection.

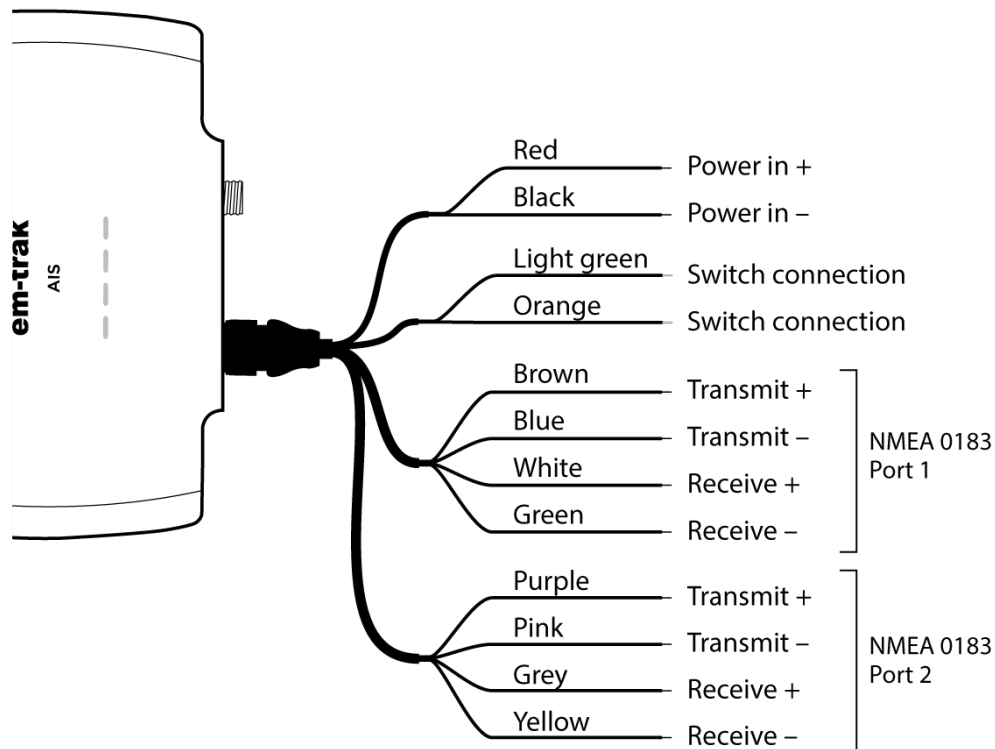

Figure 9 : Power and data cable connections

The table below lists the function of each colour coded wire for reference.

Wire colour	Description	Function
Red	Power in +	Power supply connections
Black	Power in -	
Light green	Switch connection	External switch connections for silent mode
Orange	Switch connection	
Brown	NMEA 0183 port 1 TX+	High speed NMEA 0183 output (38,400baud) intended for connection to chart plotters
Blue	NMEA 0183 port 1 TX-	
White	NMEA 0183 port 1 RX+	
Green	NMEA 0183 port 1 RX-	
Purple	NMEA 0183 port 2 TX+	Low speed NMEA port (4,800baud) intended for connection to other NMEA 0183 compatible sensors for multiplexing of data to the chart plotter
Pink	NMEA 0183 port 2 TX-	
Grey	NMEA 0183 port 2 RX+	
Yellow	NMEA 0183 port 2 RX-	



Check your wiring very carefully before applying power to the product. Failure to wire the product correctly could result in permanent damage.

The AIS transceiver is designed to operate at voltages from 9.6-31.2V, however for optimum performance we would recommend maintaining the voltage range at 12-24V.

It is recommended that crimped and soldered lugs are used to connect the AIS transceiver to the power source using a suitable circuit breaker and/or 3A fuse block. The red and black wires as shown in Figure 10 need to be connected as follows:

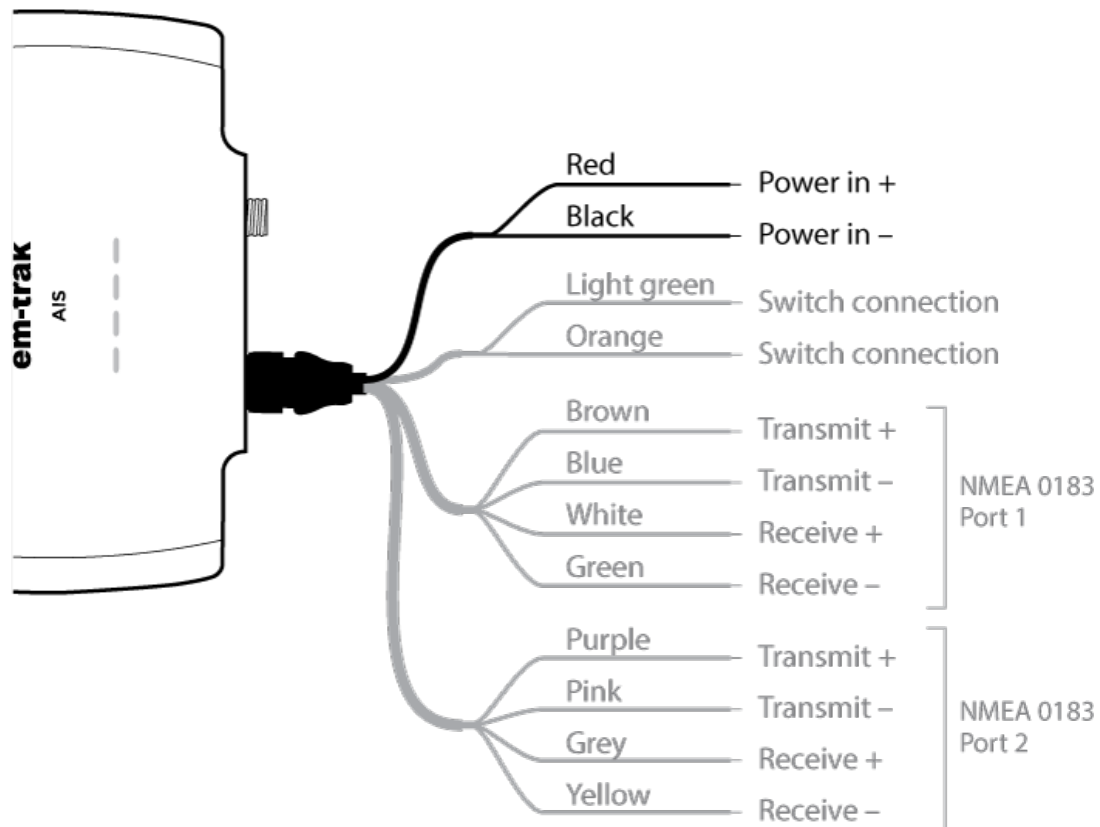

Figure 10 : Connecting the power supply

4.4 Location and fixing of the transceiver

- The ambient temperature around the transceiver should be maintained between -25°C and +55°C.
- The transceiver should not be located in a flammable or hazardous atmosphere, such as in an engine room or near to fuel tanks.
- The transceiver must be fitted in a location where it is at least 0.2m from a compass or any magnetic device.
- The transceiver should be mounted in a location where the LED indicators are readily visible as they provide important information on the status of the transceiver.
- Wi-Fi & Bluetooth enabled variants (B922/B924/B952/B954) will benefit from being installed near the center of the boat to provide a consistent signal across all areas. The construction of your vessel can also have an impact on performance. For example, metal structural bulk heads and roofing, power cables and reflective surfaces can reduce, and in certain situations block, the signal. Consider testing the reception to ensure you're happy before you mount the bracket and transceiver.
- For optimum performance the transceiver should be mounted at least 0.5m away from other high power transmitting equipment like VHF radios.
- There should be adequate space around the transceiver for routing of cables. See Figure 11 for details of the transceiver dimensions.

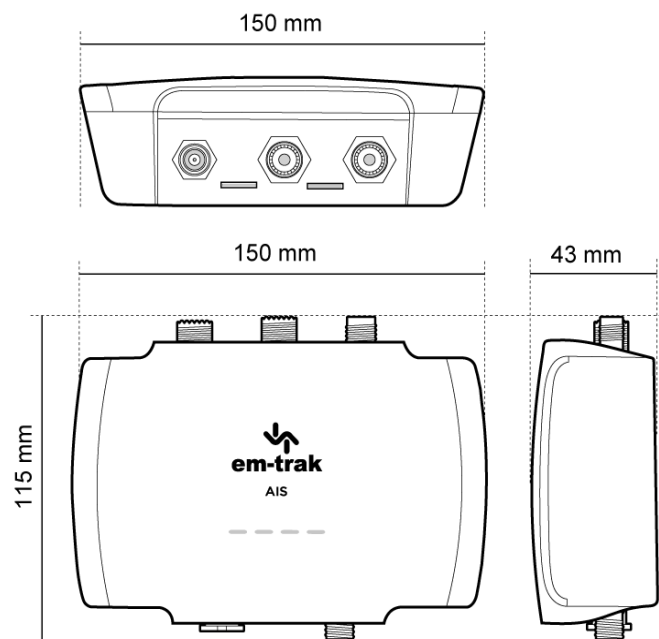

Figure 11 : Transceiver dimensions

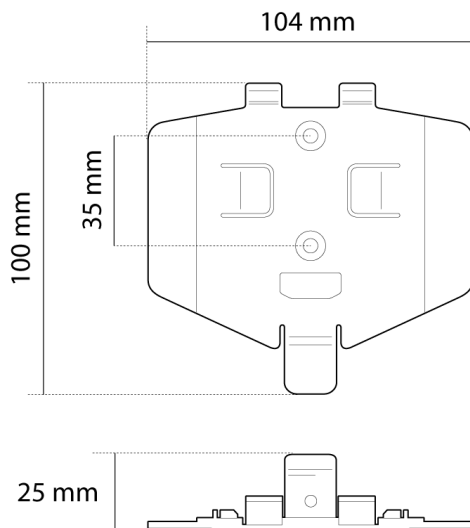

Figure 12 : FLEXI-FIT bracket

The B900 Series uses a simple bracket system to make installation as easy as possible. Use the bracket as a template to locate the desired position of the transceiver and simply screw or stick (adhesive pads are also supplied) the bracket to your vessel and then click the transceiver into the bracket. The secure clip will hold the transceiver securely in even the most severe weather and waveshocks.

To unclip the transceiver no tools are required. Simply push the release clip on the bracket with a finger or thumb and carefully rotate the transceiver and lift off the bracket.

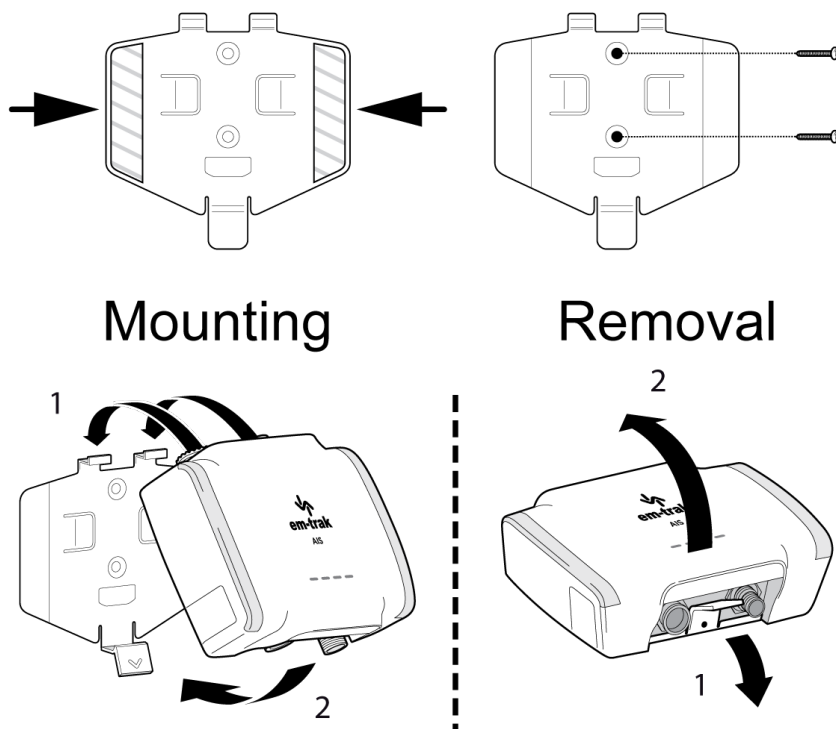

Figure 13 : AIS transceiver mounting

4.5 Configuration

Your transceiver will only be able to transmit once it has been configured with appropriate vessel data.

4.5.1 Switching on your AIS transceiver for the first time

When power is applied to the transceiver for the first time all the status LED indicators will flash briefly, leaving only the amber and red LED indicators illuminated. You will now need to configure your transceiver, after which only the green LED will be illuminated.

4.5.2 Configuring your AIS transceiver

Depending on the variant of transceiver there are three ways in which your AIS transceiver can be configured.

Method 1: Configuration in advance by your dealer or installer.

If your AIS transceiver has been configured for you by your dealer or installer you can proceed to "Connectivity" on page 24. This is required for customers who have a US-registered vessel.

Method 2: Configuration using your PC

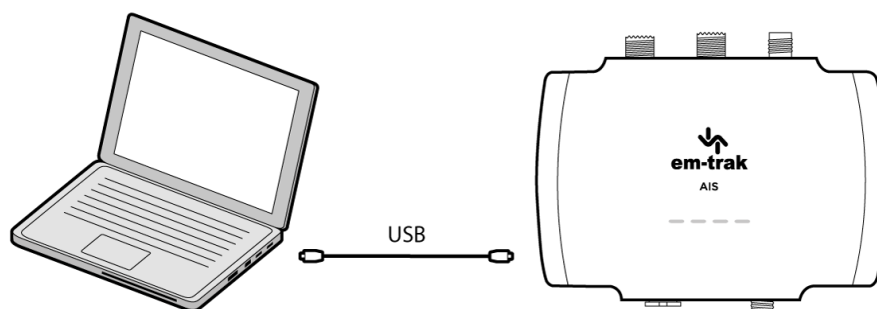

Figure 14 : Configuration using your P.C

Method 3: Configuration using your smartphone



Figure 15 : Configuration using your smartphone

4.6 Introduction to proAIS2

proAIS2 is available for download from www.em-trak.com/ installation and allows you to configure your transceiver using a PC or laptop over USB.

This configuration tool can be used to configure your vessel data, check the GPS antenna performance, view details on surrounding vessels, and monitor and diagnose the performance of the transceiver.

4.6.1 Installing proAIS2

1. Download and extract the zip file to your local PC or laptop. For Windows installations you will need to open the appropriate folder and run the setup.exe or proAIS2.msi files before following the on-screen prompts. For macOS installations you will need to open the appropriate folder and run the proAIS2.dmg file.
2. If a security warning appears, click 'Install' to continue with the installation.
3. For Windows installations, the USB drivers can be optionally installed at the same time. This is recommended for most installations and will be required to allow your PC or laptop to recognise the transceiver COM port. Once installation is complete, a start menu folder and shortcut can be created for future use.

4.6.2 Vessel data configuration using proAIS2

For configuration purposes only, it is possible to power the AIS transceiver using USB only. This is useful if you wish to configure your AIS transceiver away from the vessel power supply. The AIS transceiver will not transmit or receive any data whilst powered by USB only.

You will require the following information in order to configure your AIS transceiver:

- MMSI
- Vessel name
- Vessel type
- Vessel dimensions and position of your GPS antenna installation



Ensure that you enter all vessel data accurately. Failure to do so could result in other vessels failing to identify your vessel correctly. The vessel MMSI can only be configured once using proAIS2. If you need to change the MMSI for any reason, contact your dealer or support@em-trak.com and provide the product serial number, current MMSI number and new MMSI number.

4.6.3 Wi-Fi configuration using proAIS2

This section applies to Wi-Fi & Bluetooth enabled variants (B922, B924, B952 and B954). The Wi-Fi interface can be configured using the Wi-Fi tab.

4.6.4 Access point mode

This mode enables your transceiver to create its own network. The following parameters can be configured:

- AP SSID (the default is <B900 model>_<alphanumeric number>)
- IP address (the default is 192.168.2.1)
- Password (the default is emtrakais)
- Port (the default is 5000)

Access point mode supports data streaming to two clients simultaneously.

4.6.5 Station mode

This mode enables your transceiver to connect to an existing network as a client. The following parameters can be configured:

- Host name
- SSID
- Password
- DHCP / Fixed IP address, Subnet, Gateway
- Port number
- Protocol
- Encryption on/off

DHCP mode is recommended if you are not familiar with networks and the router supports it. There is also an option to completely turn off Wi-Fi if required.

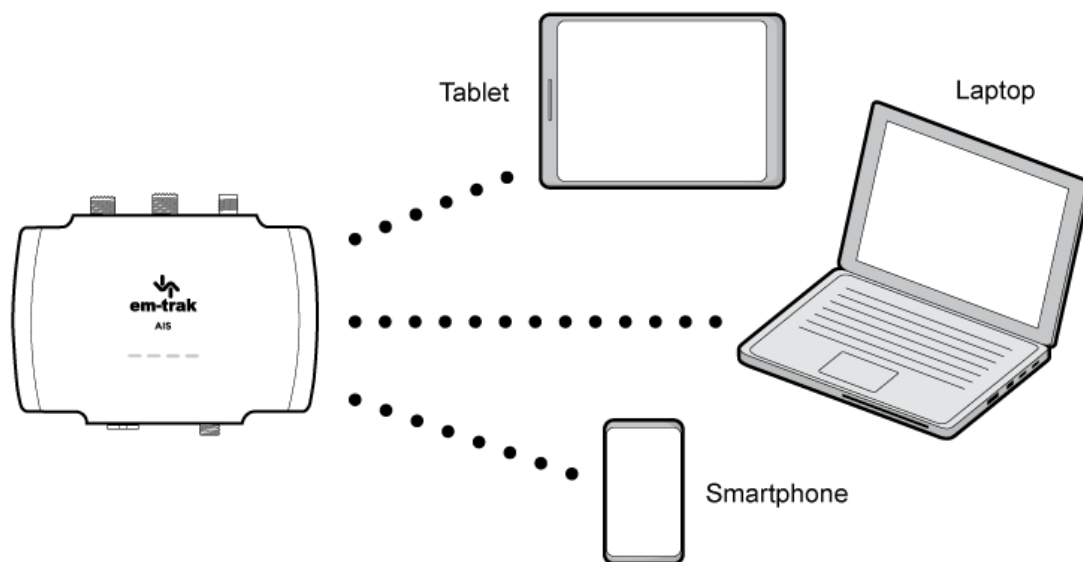

Figure 16 : Typical mobile devices for Wi-Fi & Bluetooth connection

4.6.6 Bluetooth

The Bluetooth interface uses the same ID as the default Wi-Fi AP SSID.

For security purposes there is a 10 minute window from initialisation where the Bluetooth interface is available for pairing. After this window expires it will disappear from device lists. Active connections will not be affected by this. If you wish to make the Bluetooth interface visible again for a further 10 minutes you will need to completely remove and reapply the power (including USB). The Bluetooth interface supports data streaming to seven devices simultaneously.

There is also an option to completely turn off Bluetooth if required.

The Bluetooth interface is not supported by Apple devices.

4.6.7 Introduction to CONNECT-AIS

Wi-Fi & Bluetooth variants of the transceiver (B922/B924/B952/ B954) can be configured using the CONNECT-AIS app.

CONNECT-AIS is available for download from Google Play and the App Store.

This configuration tool can be used to configure your vessel data, check the GPS antenna performance, view details on surrounding vessels, and monitor and diagnose the performance of the transceiver.

Further information on how to use CONNECT-AIS can be found in the FAQ section for this product - <https://em-trak.com/installation/>.

4.7 Connectivity

4.7.1 Connecting to an NMEA 2000 network

The transceiver can be connected to an existing NMEA 2000 network to provide AIS and position data to other connected devices such as chartplotters, instruments, sensors, etc.

Connection is made by a Micro-C drop cable to the existing NMEA 2000 network T-piece. This item is not supplied so you will need to purchase one from your local dealer.

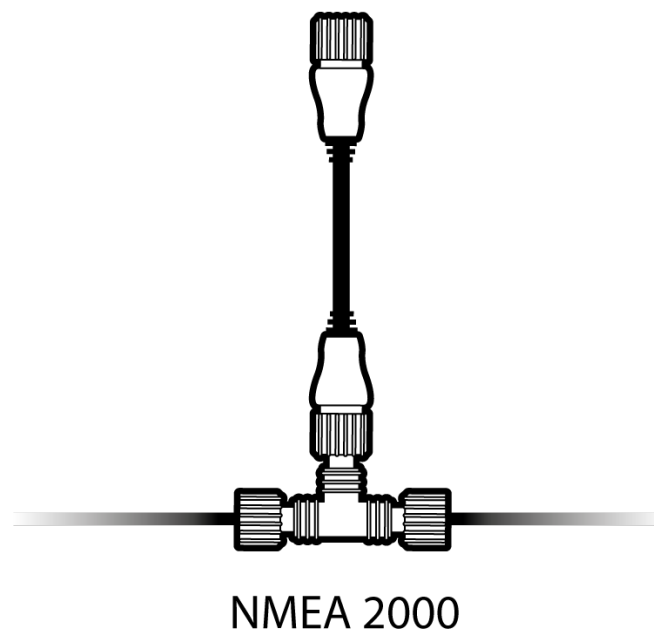

Figure 17 : NMEA 2000 network connection



The transceiver will only operate on a 12V NMEA 2000 network.

Connecting the transceiver to a 24 volt NMEA 2000 network may result in damage and will void the warranty.

Note that the transceiver cannot be powered by the NMEA 2000 network, it will also require external power using the supplied power cable.

Starter kits are available to purchase if you do not already have an NMEA 2000 network.

The list of supported NMEA 2000 data (PGN's) is detailed in "PGN table" on page 30.

4.7.2 Connecting to your chartplotter

NMEA 0183 port 1 is recommended for connecting to a chartplotter, operating at 38,400 baud by default. This can be changed using the configuration tools if required. Four wires are provided for a bidirectional connection, and are colour coded as shown in Figure 18.

Other manufacturers may use different signal names, however the following general guidelines will apply when connecting to other equipment:

- positive signals should be connected together.
- negative signals should be connected together.
- transmit signals should be connected to receive signals and vice versa.

Refer to your equipment manual for more information. Both NMEA 0183 ports support multiplexing, which means that any data received on port 1 will be automatically output on port 2, and vice versa.

This can be useful when connecting to a chartplotter that only has a single NMEA 0183 port, so a sensor can be connected to port 2 on the transceiver, and the combined sensor and AIS data will be output on port 1.

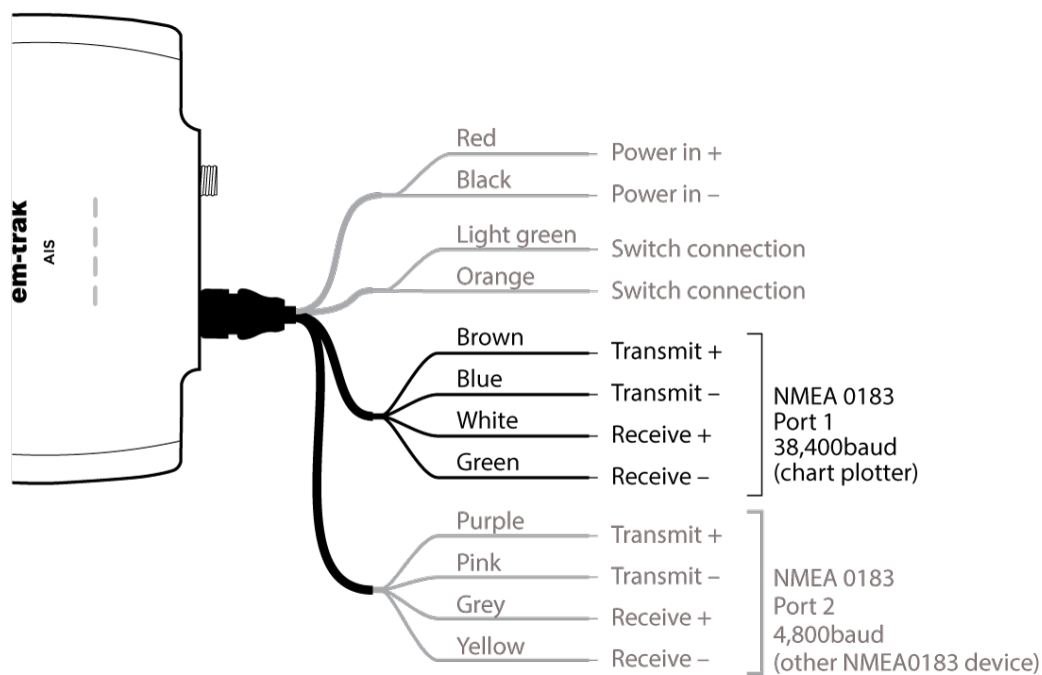

Figure 18 : Connecting to your chartplotter

4.8 Connecting to your NMEA 0183 sensor

NMEA 0183 port 2 is recommended for connecting to your sensor or NMEA 0183 compatible equipment operating at 4,800baud by default. This can be changed using the configuration tools if required. Four wires are provided for a bi-directional connection, and are colour coded as shown in Figure 19.

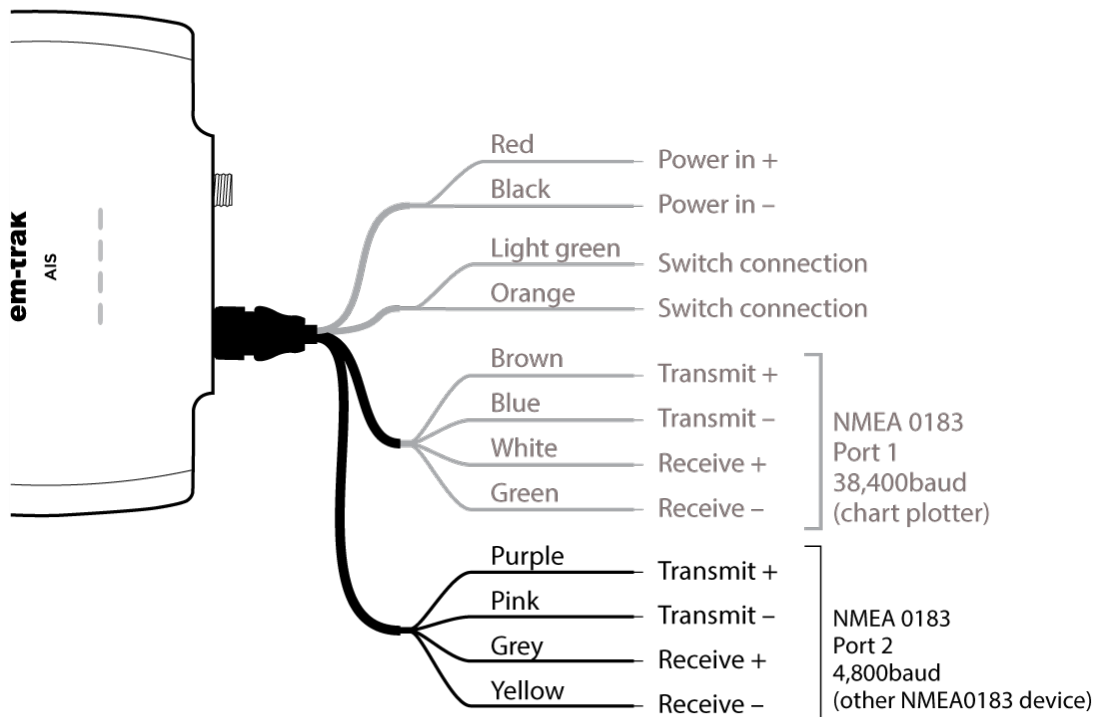



Figure 19 : Connecting to your NMEA 0183 sensor

4.8.1 Connecting to your PC

A Micro-USB cable (supplied) will be required to connect the transceiver to a PC or laptop. USB drivers will need to be installed for Windows operating systems (Windows 7 and up). These are installed automatically by using either Windows Update or when installing proAIS2. proAIS2 is available for download from www.emtrak.com/installation.

USB drivers are typically not required for macOS operating systems.

 To maintain the waterproof seal ensure the rubber bung is securely refitted after using the USB interface.

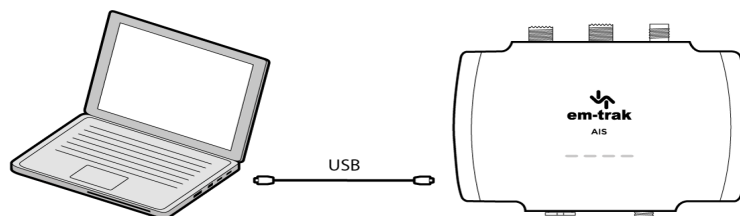

Figure 20 : Connecting to your PC

4.8.2 Wi-Fi and Bluetooth connectivity

Wi-Fi & Bluetooth enabled variants (B922/B924/B952/B954) can be connected wirelessly to a mobile device.

The Bluetooth interface is not supported by Apple devices.

To establish a connection with a mobile device you will need to select your transceiver from its list of detected devices using the device name or SSID - at default it appears as <B900 model>_<alphanumeric number> but it can be changed using the Wi-Fi tab on proAIS2 if required.

To stream AIS data to a navigation application you may then need to enter the IP address and port number. This is also displayed in the Wi-Fi tab of proAIS2 and can be changed if required.

Contact support@em-trak.com if you require any assistance with the wireless configuration of your transceiver.

5 Operation

5.1 LED indicators

5.1.1 Using the AIS transceiver

Once the unit has been configured it is ready for use. Providing other vessels installed with transceivers are within radio range of your vessel you will see their details appear on the display devices that you have connected to your transceiver. Note that your full vessel details may not be visible to other vessels immediately as static data messages (containing vessel name, call sign, etc) are required to be transmitted every 6 minutes.

5.1.2 LED indicator functions

The AIS transceiver includes four coloured LED indicators as shown in Figure 21. The state of the LED indicators provide information regarding the status of the AIS transceiver.

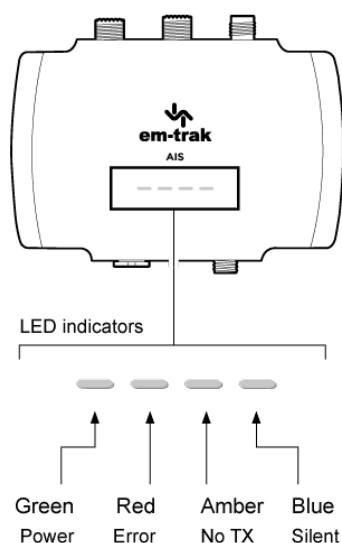





Figure 21 : LED indicator location on the AIS transceiver unit

The meaning of each LED indicator is shown in the table below. Figure 21 shows the LED indicator positions on the AIS transceiver.

LED	Function
	<p>Green LED indicator</p> <p>Indicates that the AIS transceiver is configured, powered up and has transmitted (B92x variants). Indicates that the AIS transceiver is configured and powered up (B95x variants).</p>
	<p>Red LED indicator</p> <p>Indicates that the AIS transceiver has detected a system error. The likely causes of this are detailed in the troubleshooting guide in Section 5. Alarms displayed in the Diagnostic tab of proAIS2 or in CONNECT-AIS will also assist with troubleshooting.</p>
	<p>Blue LED indicator</p> <p>Indicates that silent mode is enabled. Silent mode is a feature of the B900 Series that ceases the transmissions from your own vessel, whilst the reception of other vessel position reports continue.</p> <p>You can activate this using the configuration tools or by activating the toggle switch as detailed in "Silent mode" on the facing page.</p>



Amber LED indicator

- If the LED indicator is flashing it means it is attempting to get a GPS fix. The GPS antenna status can be confirmed using the configuration tools.
- If the LED indicator is solid it means that the AIS transceiver is not transmitting. This can be for a number of reasons including:
 - The AIS radio channels are exceptionally busy so there are currently no available slots for transmission.
 - The unit has been in silent mode and after deactivating silent mode this amber LED indicator will illuminate until the first AIS message has been sent
 - The AIS transceiver has been commanded by the local authority (via an AIS base station) to cease transmissions.

5.2 Silent mode

An external switch enables / disables 'silent mode'. In silent mode the transmission of your own vessel position ceases, whilst the reception of other vessel's AIS position continues. When silent mode is active the blue LED indicator will be illuminated. This is also reflected in the Diagnostics tab of proAIS2 or in CONNECT-AIS.



When silent mode is active other vessels will not be able to receive your vessel information on their AIS devices. Your navigational safety may be compromised as a result.

Connect the toggle switch between the light green and orange wires as shown in Figure 22. This is optional and not essential for normal operation of the product.



Do not connect a voltage source across the switch inputs as this may damage the transceiver.

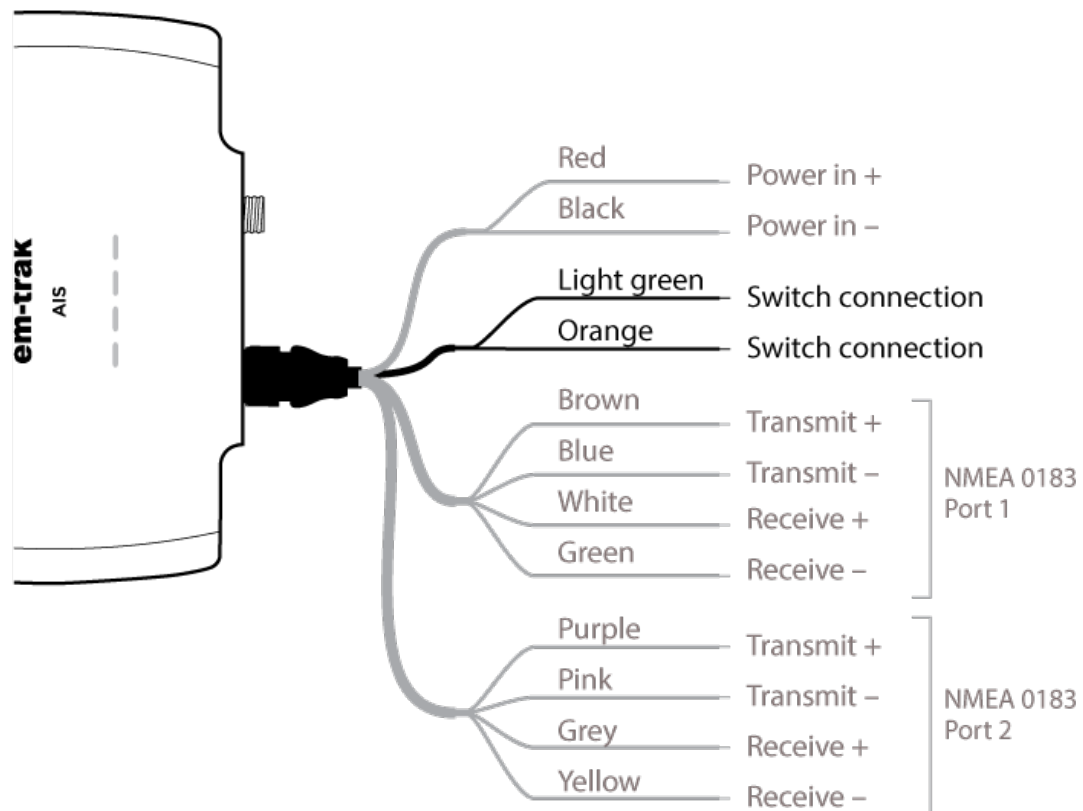

Figure 22 : Connecting an external switch

5.3 PGN table

Parameter Group Numbers (PGN's) are useful for understanding the detailed information that your transceiver receives and transmits on an NMEA 2000 network. The PGN's listed below are supported by the transceiver. There are no unused fields.

PGN	Title in NMEA database	Usage	NMEA 0183
059392	ISO Acknowledgment	in, out	
059904	ISO Request	in, out	
060416	ISO Transport Protocol - Data	in, out	
060160	ISO Transport Protocol - Connection	in, out	
060928	ISO Address Claim	in, out	
065240	ISO Command Address	in	
126208	Group Function	in, out	
126464	PGN list - Group Function	in, out	
126992	System time	out	
126993	Heartbeat	out	
126996	Product Information	in, out	
126998	Configuration Information	out	
129025	Position, Rapid Update	out	RMC

129026	COG & SOG. Rapid Update	out	RMC
129029	GNSS Position data	out	RMC
129038	AIS Class A Position Report	out	VDM/VDO
129039	AIS Class B Position Report	out	VDM/VDO
129040	AIS Class B Extended Position Report	out	VDM/VDO
129041	AIS AtoN Report	out	VDM/VDO
129793	AIS UTC and Date Report	out	VDM/VDO
129794	AIS Class A Static and Voyage Related Data	out	VDM/VDO
129795	AIS Addressed Binary Message	out	VDM/VDO
129796	AIS Acknowledge	out	VDM/VDO
129797	AIS Binary Broadcast Message	out	VDM/VDO
129798	AIS SAR Aircraft Position Report	out	VDM/VDO
129801	AIS Addressed SRM	out	VDM/VDO
129802	AIS Safety Broadcast Binary Message	out	VDM/VDO
129809	AIS Class B CS Static Data Report Part A	out	VDM/VDO
129810	AIS Class B CS Static Data Report Part B	out	VDM/VDO

5.3.1 NMEA conversions

The tables below show conversions from NMEA 2000 to NMEA 0183 , and NMEA 0183 to NMEA 2000.

All converted NMEA PGNs shall be multiplexed to all NMEA 0183 output ports, that is NMEA 0183 ports 1 & 2, any USB ports as well as all Wi-Fi and Bluetooth connections.

Conversion from NMEA 2000 to NMEA 0183		
Data	PGN	NMEA 0183
Vessel heading	127250	HDG
Vessel heading	127250	THS
Magnetic variation	127258	HDG
Speed, water referenced	128259	VHW
Water depth	128267	DPT
Distance log	128275	VLW
Cross track error	129283	XTE
Navigation data	129284	RMB
Wind data	130306	MWD
Wind data	130306	MWV
Environmental (Water temperature)	130310	MTW
Environmental (Water	130311	MTW

temperature)		
Environmental (Water Temperature)	130312	MTW
Environmental	130314	MDA

Conversion from NMEA 0183 to NMEA 2000		
Data	NMEA 0183	PGN
Heading, deviation and variation	HDG	127250
Heading true	HDT	127250
Heading, deviation and variation	HDG	127258
Cross track error	XTE	129283
Recommended minimum navigation information	RMB	129283
Recommended minimum navigation information	RMB	129284

6 Troubleshooting

Issue	Possible cause and remedy
No LED indicators are illuminated	<ul style="list-style-type: none"> • Check that the power supply is connected correctly. • Check that the power supply is a 12V or 24V supply.
The red error LED indicator is flashing	<p>There may be a problem with the VHF antenna system. This can be confirmed using the configuration tools. If the 'High VSWR' alarm is active, check for the following:</p> <ul style="list-style-type: none"> • Faulty VHF antenna/cable/connectors. • Poor connection at the VHF antenna/cable/connectors. • Suitability of the VHF antenna. For B921/B922/B951/B952 an antenna tuned for AIS at 162MHz is recommended. For variants with a splitter (B923/B924/B953/B954) an antenna tuned to operate across the frequency range 156MHz to 162MHz is required. • VHF antenna location (ensure that is isn't mounted near other transmitting antennas or sources of interference, metal structures, or other obstructions). • Check that the unit is configured with a valid MMSI number. This can be confirmed using the Configuration tools. • Check that the GPS antenna has a stable position fix. This can be confirmed using the configuration tools. • Check that the power supply is within 9.6 - 31.2V. This can be confirmed using the configuration tools.
The amber LED indicator is flashing continuously	<ul style="list-style-type: none"> • The amber LED indicator flashes while the transceiver searches for a position fix. If it takes longer than a minute you can check the performance of the GPS antenna by using the configuration tools.
No data is being received by the chart plotter	<ul style="list-style-type: none"> • Check that the signal wires are connected correctly. • Check that the baud rate matches both the transceiver and the chart plotter. • Confirm that other vessels are within radio range and that they are displayed on the Other Vessels tab of proAIS2 or CONNECTAIS.
My vessel name isn't being received by other vessels	<ul style="list-style-type: none"> • Static data (containing vessel name, call sign, etc) is transmitted every 6 minutes so it may take a few transmissions before all the vessel data is displayed. • Position reports contain critical data like position, MMSI number, vessel speed, etc and these are transmitted more regularly.
I can't establish a connection using Wi-Fi or	<ul style="list-style-type: none"> • Check that the transceiver is powered by 12 - 24V. • Check the configuration parameters using proAIS2.

Bluetooth	<ul style="list-style-type: none">• Check that there are no obstructions between the transceiver and mobile device.• Check that there are no sources of interference nearby.• Check that the 10 minute Bluetooth pairing window hasn't expired. If it has, you will need to completely remove and reapply the power (including USB).• Check that you're not attempting to use Bluetooth with an Apple device.
-----------	--

If the guidance given above does not rectify the problem you are experiencing, contact your dealer or support@em-trak.com for further assistance.

7 Specifications

Parameter	Value
Dimensions	149 x 118 x 47 mm (L x W x H)
Weight	Transceiver only variants 320g Transceiver with splitter variants 345g
Input voltage	DC 12 - 24V (9.6 - 31.2V maximum)
Average power consumption	B921/B951: 135mA / 1.65W at 12V B922/B952: 170mA / 2.05W at 12V B923/B953: 245mA / 2.95W at 12V B924/B954: 280mA / 3.35W at 12V
Peak current rating	B921/B922/B951/B952: 2A B923/B924/B953/B954: 2.5A
GPS Receiver (AIS integrated)	72 channel IEC 61108-1 compliant L1 GPS band 1575.42MHz L1 GLONASS band 1597.1-1609.5MHz E1 Galileo band 1575.42MHz B1 BeiDou band 1561.098MHz
Electrical Interfaces	NMEA 0183 4,800 baud NMEA 2000 LEN=1 Wi-Fi 2.4GHz IEEE 802.11 a/b/g/n Output power +15dBm Bluetooth V4.0 / Output power +11dBm
Connectors	VHF antenna connector (SO-239) VHF radio connector (SO-239) - only applicable to splitter variants B923/B924/B953/B954 External GPS antenna connector (TNC) NMEA 2000 connector (Micro-C) Power/NMEA 0183/silent mode (12 way) Micro-USB connector
VHF Transceiver	Transmitter x 1 Receiver x 2 (Receivers time shared between AIS and DSC) Frequency: 156.025 to 162.025 MHz in 25 kHz steps
Output Power CSTDMA	33dBm \pm 1.5 dB
Output Power SOTDMA	37dBm \pm 1.5 dB
Channel Bandwidth	25kHz

Channel Step	25kHz
Modulation Modes	25kHz GMSK (AIS, TX and RX)
	25kHz AFSK (DSC, RX only)
Bit rate	9600 b/s \pm 50 ppm (GMSK)
	1200 b/s \pm 30 ppm (FSK)
Receiver Performance	Sensitivity better than -107dBm at 20% PER
	Co-channel 10dB
	Adjacent channel 70dB
	IMD 65dB
	Blocking 86dB
Environmental	Weather and waterproof to IPx7 & IPx6
	Operating temperature: -25°C to +55°C
	Tested to IEC 60945 'Exposed' category
LED indicators	Power, TX status, error, silent mode status

Head office:

em-trak Marine Electronics Ltd
Wireless House
Westfield Industrial Estate
Midsomer Norton
Bath, BA3 4BS
England UK
T +44 (0)1761 409559 | F +44 (0)1761 410093
enquiries@em-trak.com

Regional office:

em-trak Marine Electronics Ltd
470 Atlantic Avenue
4th floor,
Boston MA 02210
USA
T +1 617 273 8395 | F +1 617 273 8001
enquiries@em-trak.com

Support: support@em-trak.com | Sales: enquires@em-trak.com | Website: www.em-trak.com